

# *D. Gillespie Designs*

## **ST-35 Capacitor Board**

with **EFB<sup>TM</sup>**



## **PC Board Assembly**

Thank you for purchasing our ST-35 Capacitor Board with \*EFB™. We feel it is the single most significant upgrade you can make to your ST-35. It is designed to integrate into your Dynaco ST-35 amplifier without chassis modifications of any kind.

Upgrading your ST-35 with the Capacitor / EFB board consists of two stages. The first, covered in this document, involves assembling the PC board. The second continues with installing the assembled PC board in the ST-35, and is covered in a separate installation manual.

## ! Please note before continuing:

### Proper Soldering is Vital

It is assumed that you possess the necessary skills and equipment to properly solder components to a printed circuit board. The majority of problems encountered after assembly are directly related to poor solder connections, such as “cold” joints, or solder “bridges” resulting in unintended connections between components.

### Polarized Components

The electrolytic capacitors and diodes employed on the board are “polar”. Electrolytic capacitors have specific positive and negative leads, while diodes can only pass current in one direction, thus it is imperative that they be installed in the PC board in the correct orientation. Failure to do so can result in damage to the components, as well as failure of the board to function properly.

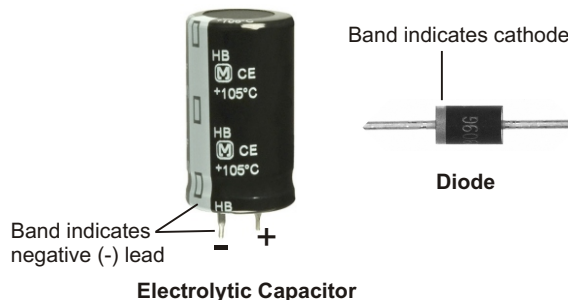

### Color Coded Components

Most of the resistors on the board will be coded with colored rings which denote their value and tolerance. If you are not familiar with the color coding system it is advisable to check the value of each resistor with an ohmmeter before installing it in the board.

## Assembly Procedure:

### General Notes

When installing axial components, like resistors and diodes, for neatest appearance, pre-bend the leads with small needle-nosed pliers such that the leads align with the associated holes on the board. This will also allow the components to sit flat against the board when installed.



After inserting the component leads into the respective holes on the board, bend the leads outward slightly. This will prevent the component from falling out of the board when it is turned over for the soldering procedure.

- ( ) Install the 0.5W metal film resistors R1, R2, R3, R4, R5. Solder the leads to the pads and trim excess lead length.
- ( ) Install the Diodes D1, D2. **Be sure to install the diodes in the direction indicated by the cathode band on the diodes and the board assembly diagram on page 5.** Solder the leads to the pads and trim excess lead length.
- ( ) Install the 1W metal oxide resistors R6, R7, R11. Solder the leads to the pads and trim excess lead length.
- ( ) Install the Trimmer Potentiometer P1. Solder the leads to the pads and trim excess lead length.

## Assembly Procedure Ctd.

- ( ) Install the Test Jacks LC, RC, COM. Solder the leads to the pads. It is not necessary to trim any excess lead length. Note: having only a single lead, the jacks will tend to fall out of the board when it is turned over to solder. You may find it helpful to secure the jacks to the top side of the board using small pieces of masking tape during the soldering process.
- ( ) Install the 50 ohm 5W wire wound resistor R12. Solder the leads to the pads and trim excess lead length.
- ( ) Install the 0.1uF/450V polypropylene capacitors C1, C3. Solder the leads to the pads and trim excess lead length.
- ( ) Install the 120uF/50V electrolytic capacitor C8D. **Be sure to install in the direction indicated by the + marking on the board and the diagram on page 5.** Solder the leads to the pads and trim excess lead length.
- ( ) Install the 47uF/450V electrolytic capacitor C8 A. **Be sure to install in the direction indicated by the + marking on the board and the diagram on page 5.** Solder the leads to the pads and trim excess lead length.
- ( ) Install the 4.7uF/35V electrolytic capacitor C4. **Be sure to install in the direction indicated by the + marking on the board and the diagram on page 5.** Solder the leads to the pads and trim excess lead length. **Note: The lead spacing for this capacitor is very close. Be very careful to avoid creating a solder bridge between the connection pads. Confirm using a magnifying glass, if necessary.**
- ( ) Install the 120uF/450V electrolytic capacitors C8 B, C8 C. **Be sure to install in the direction indicated by the + markings on the board and the diagram on page 5.** Note that these capacitors have "snap-in" type leads and thus will require a little effort to press into place. Solder the leads to the pads and trim excess lead length.
- ( ) Mount the Voltage Regulator VR1 to the heatsink as shown in the diagram on page 5. Apply a very thin coating of silicone grease to the back side of the regulator, then tighten the mounting screw securely. It is important to keep the regulator vertical while tightening so that it will properly align with the mounting holes on the board.
- ( ) Install the heatsink / voltage regulator assembly on the board. Solder the large heatsink mounting lugs first, then the voltage regulator leads. Trim the excess lead length from the regulator. It will take a bit of manual dexterity to hold the heatsink flat to the board while soldering the large mounting lugs, as well as considerable heat from your soldering iron. If your iron has adjustable heat settings it is likely it will need to be set for max. and/or a larger solder tip installed. **Note: The lead spacing for the regulator is very close. Be very careful to avoid creating a solder bridge between adjacent pads. Confirm using a magnifying glass, if necessary.**
- ( ) Install the five standoffs in five places as shown in the diagram on page 5  . Tighten the screws securely.

Assembly of the EFB / Capacitor Board is now complete. It is highly recommended that you double check your assembly, especially the orientation of the polarized capacitors and diodes. Also check carefully for solder bridges between the leads of C4 and VR1.

## ST EFB / Capacitor Board BOM

DESIG	DESCRIPTION	QTY.	PART NUMBER	VALUE/NOTES
R1,2,3,4	Resistor, Metal Film	4	Mouser # 273-10-RC	10 Ohms / 0.5W / 1%
R5	Resistor, Metal Film	1	Mouser # 273-15K-RC	15K / 0.5W / 1%
R6, R7	Resistor, Metal Oxide	2	Mouser # 261-180K-RC or DigiKey # 180KW-1-ND	180K / 1W / 5%
R11	Resistor, Metal Oxide	1	Mouser # 261-6.8K-RC or DigiKey # 6.8KW-1-ND	6.8K / 1W / 5%
R12	Resistor, Wirewound	2	Mouser # 594-AC05W50R00J or DigiKey # PPC5W50.0CT-ND	50 Ohms / 5W / 5%
P1	Potentiometer, Trimmer	1	Mouser # 652-3386P-1-502LF or Digikey # 3386P-502LF-ND	5K / 0.5W / ST
D1, D2	Diode, Fast Recovery	2	Mouser # 625-UF4007-E3 or Digikey # UF4007-E3/54GICT-ND	1000V / 1A
C1, C3	Capacitor, Polypropylene	2	Mouser # 667-ECW-F2W104JAQ or Digikey # P14194-ND	0.1uF / 450V / 105C
C4	Capacitor, Electrolytic	1	Mouser # 647-UJV21V4R7MDD or Digikey # 493-1313-ND	4.7uF / 35V / 105C
C8 B, C8 C	Capacitor, Electrolytic	2	Mouser # 647-LGU2W121MELZ or Digikey # 493-2852-ND	120uF / 450V / 105C
C8 A	Capacitor, Electrolytic	1	Mouser # 667-EEU-EE2W470S or Digikey # P13678-ND	47uF / 450V / 105C
C8 D	Capacitor, Electrolytic	1	Mouser # 647-UPW1H121MPD6 or Digikey # 493-1901-ND	120uF / 50V / 105C
VR1	Voltage Regulator, Adjustable	1	Mouser # 595-LM237KCSE3 or Digikey # 296-21574-5-ND	LM237 / 1.5A / 150C ! Do not Substitute
LC, RC	Test Jack, Insulated, Red	2	Mouser # 530-105-0852-1 or Digikey # J120-ND	
COM	Test Jack, Insulated, Black	1	Mouser # 530-105-0853-1 or Digikey # J121-ND	
None	Heatsink, Aluminum, TO-220, 2"	1	Mouser # 588-FA-T220-51E or Digikey # FA-T220-51E-ND	! Do not Substitute
None	Standoff, Alum., 4-40 x 0.375"	5	Mouser # 534-2202 or Digikey # 2202K-ND	
None	Machine Screw, 4-40 x 1/4"	11	Digikey # H142-ND	
None	Hex Nut, 4-40 x 1/4"	1	Digikey # H216-ND	
None	Lock Washer, Internal Tooth, #4	11	Digikey # H236-ND	
None	Thermal Grease		Digikey # 345-1006-ND	

**NOTE:** In addition, you will also require four 100 ohm/0.5W and four 1K/0.5W resistors to be used in modifying the PC-13 output board wiring as part of the EFB implementation. These correspond to Mouser part numbers 273-100-RC and 273-1K-RC respectively.

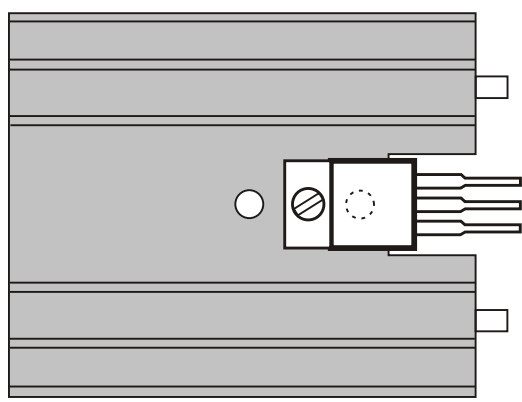
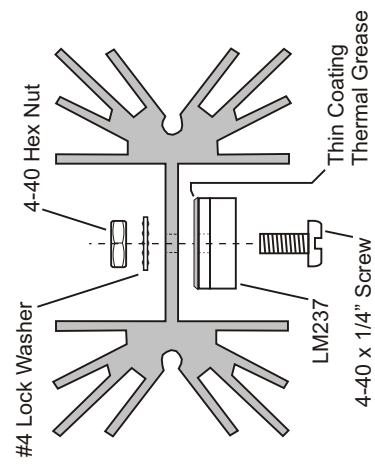
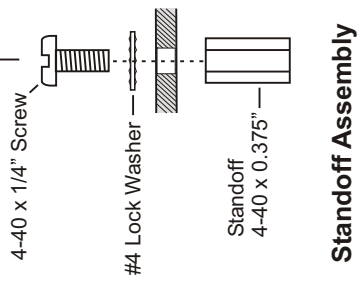
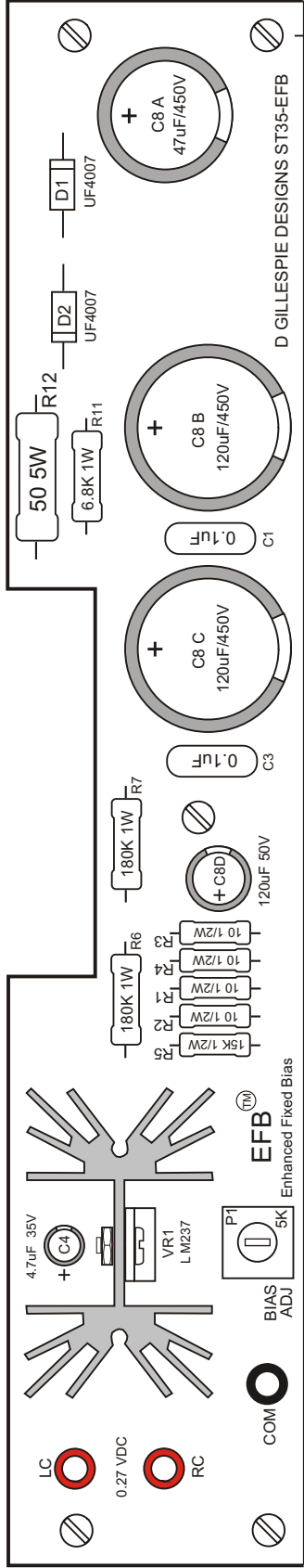

*D. Gillespie Designs*

ST-35 Capacitor Board with EFB™

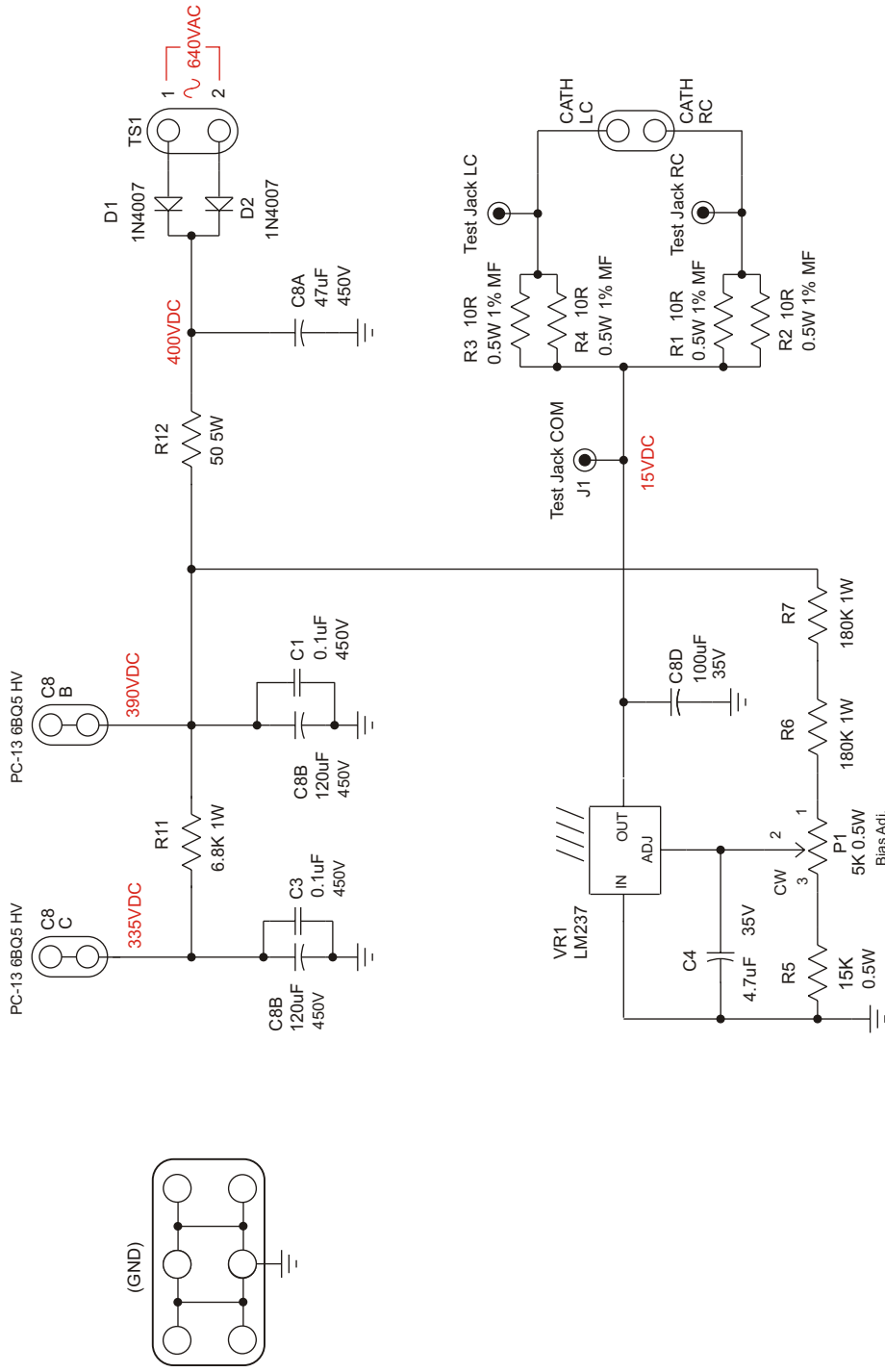

Note: DC voltages are relative to chassis ground.

*D Gillespie Designs*

ST-35 Capacitor Board with EFB<sup>TM</sup>

Schematic of the ST-35 with EFB™ board. Modifications are shown in red.

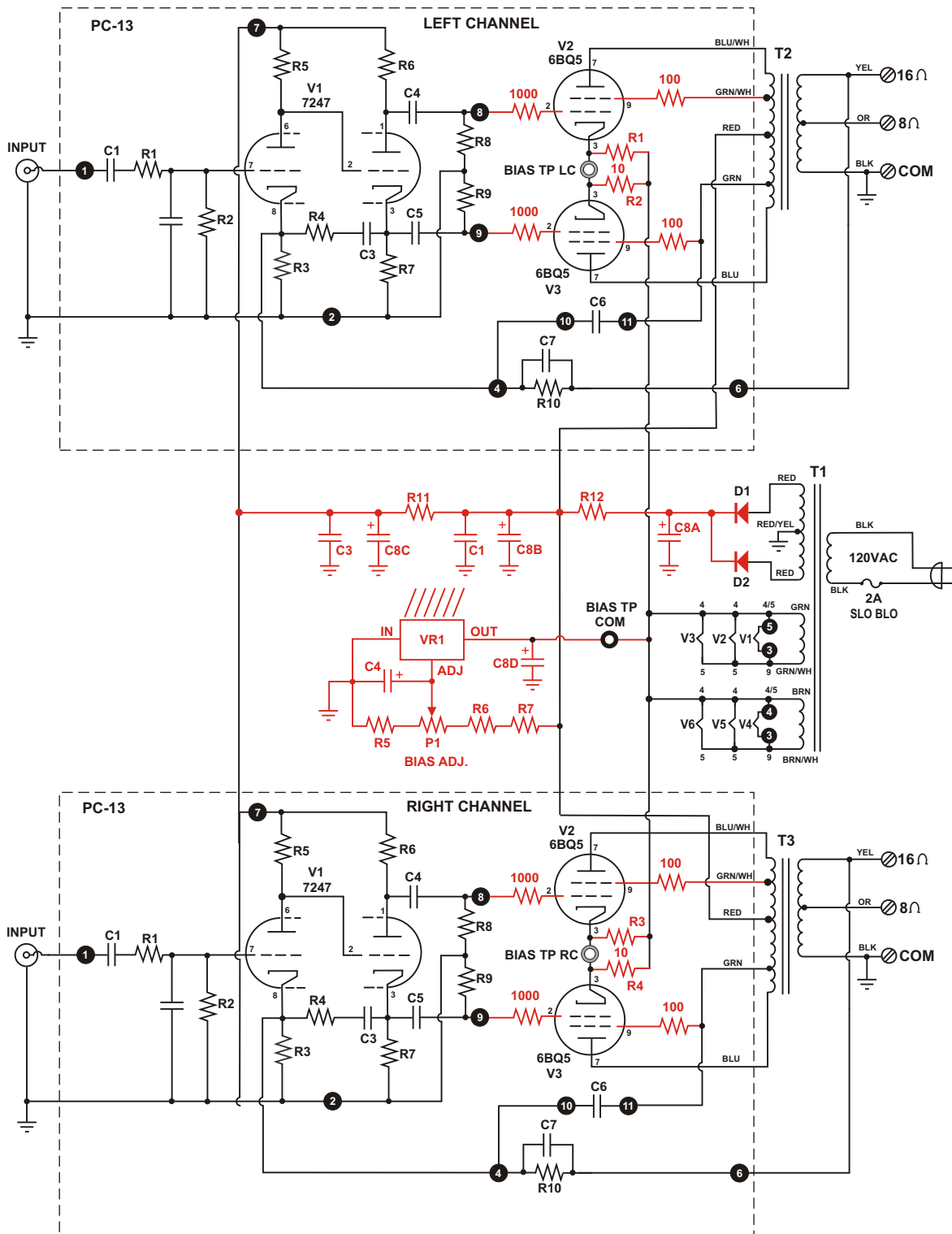

*D. Gillespie Designs*

ST-35 Capacitor Board with EFB™