

# *D. Gillespie Designs*

## **PC-13 Amplifier Board**

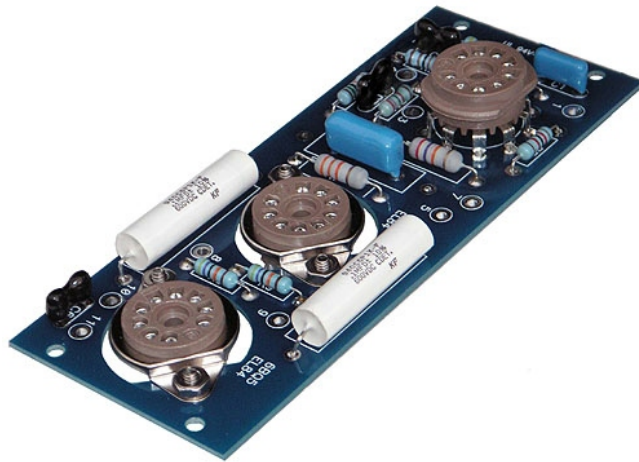

## **Installation Guide**

Thank you for choosing our PC-13 restoration board set for your Dynaco ST-35 amplifier.

The circuit remains faithful to the original Dynaco design but is implemented with high quality modern components on an FR4 fibreglass circuit board. The eyelet and mounting hole locations are consistent with the original Dynaco PC-13 circuit board.

It is assumed that you will have a copy of the original Dynaco ST-35 assembly manual to refer to when installing the PC-13 boards. If you require a manual, a free copy may be downloaded from: [www.tubes4hifi.com](http://www.tubes4hifi.com).



## HIGH VOLTAGE WARNING

Vacuum tube amplifiers contain lethal voltages. Make sure the power cord is disconnected before installing the PC-13 boards. Wait 30 minutes before removing the top and bottom covers to allow the voltage on the power supply capacitors to bleed off.

### Installation Notes:

You will be referring to the original assembly manual for the installation of the new PC-13 boards. The most difficult part of the process will be removing the existing boards, especially unsoldering the wires from the original output tube sockets. In particular, care must be taken when unsoldering the wires going to the output transformers. In some cases, the original builder will have left little or no extra length to allow you to just cut the wires off. To avoid unsightly and messy splicing these wires must be carefully unsoldered to preserve the length.

**! Note: If you are also installing the EFB Capacitor Board you must also refer to the EFB installation manual for proper wiring of the output tube sockets.**

### Useful Tools:

Desolder wick/braid and a vacuum desoldering pump are indispensable items when attempting to remove solder from existing connections. They are inexpensive and available from suppliers such as DigiKey.



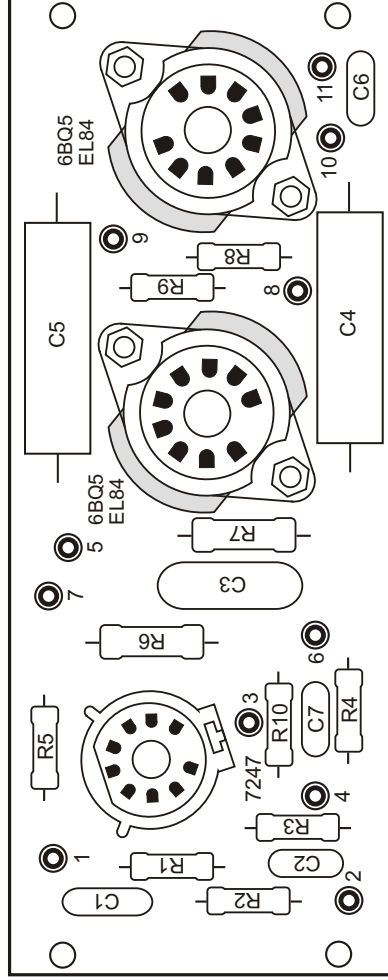

- R1 47K 0.5W
- R2 470K 0.5W
- R3 1.3K 0.5W
- R4 150K 0.5W
- R5 300K 0.5W
- R6 27K 1W
- R7 33K 1W
- R8 470K 0.5W
- R9 470K 0.5W
- R10 27K 0.5W

- C1 .1uF 250V
- C2 33pF 500V
- C3 .22uF 400V
- C4 .1uF 600V
- C5 .1uF 600V
- C6 18pF 500V
- C7 27pF 500V

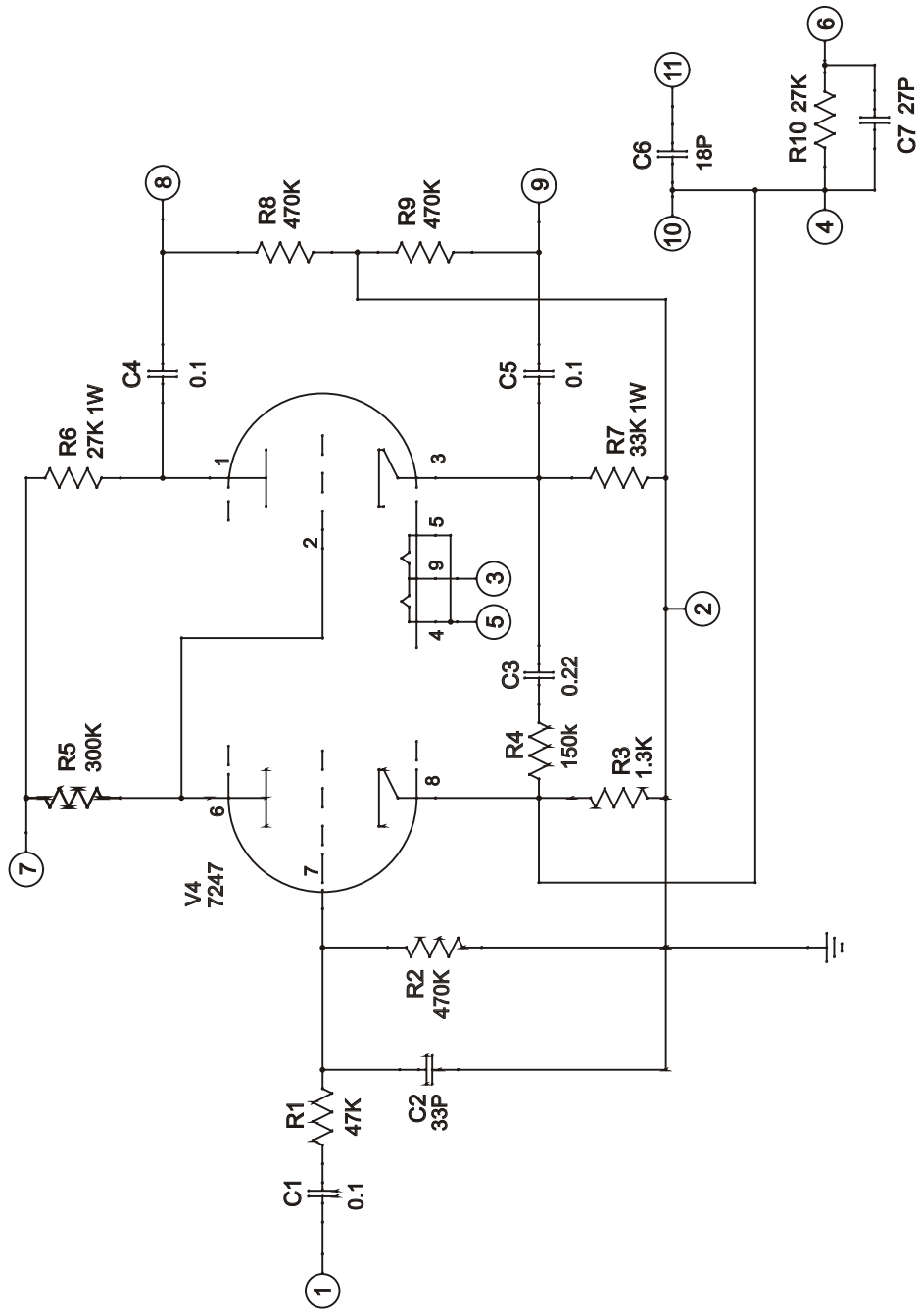

*D Gillespie Designs*

PC-13 Schematic